

Gear Motor

MTM4-LF

MTM4-LF is a hollow shaft gear motor. It can be used with DKC3 control box, DKS2 built-in spindle and DKP3 / DKP4 control panel, as a smooth and quiet solution for electric lifting table.



Feature

- Main applications: Furniture
- Input voltage: 24V DC
- Max. speed at no load: 110rpm after gear reduction
- Max. torque: 7Nm
- Dual Hall sensors positioning feedback
- Hollow shaft: Hexagon 6 mm diameter
- Noise level: ≤ 53 dB
- IP Protection level: IP30
- Color: Black
- Power cord length: 1000 mm
- Duty cycle: 10%, max. 2 min. continuous operation in 20 min.
- Ambient operation temperature: 0°C ~ +45°C
- Certified: CE marking, EMC Directive 2014/30/EU

Option

- Standard motor / High speed motor

Application example:

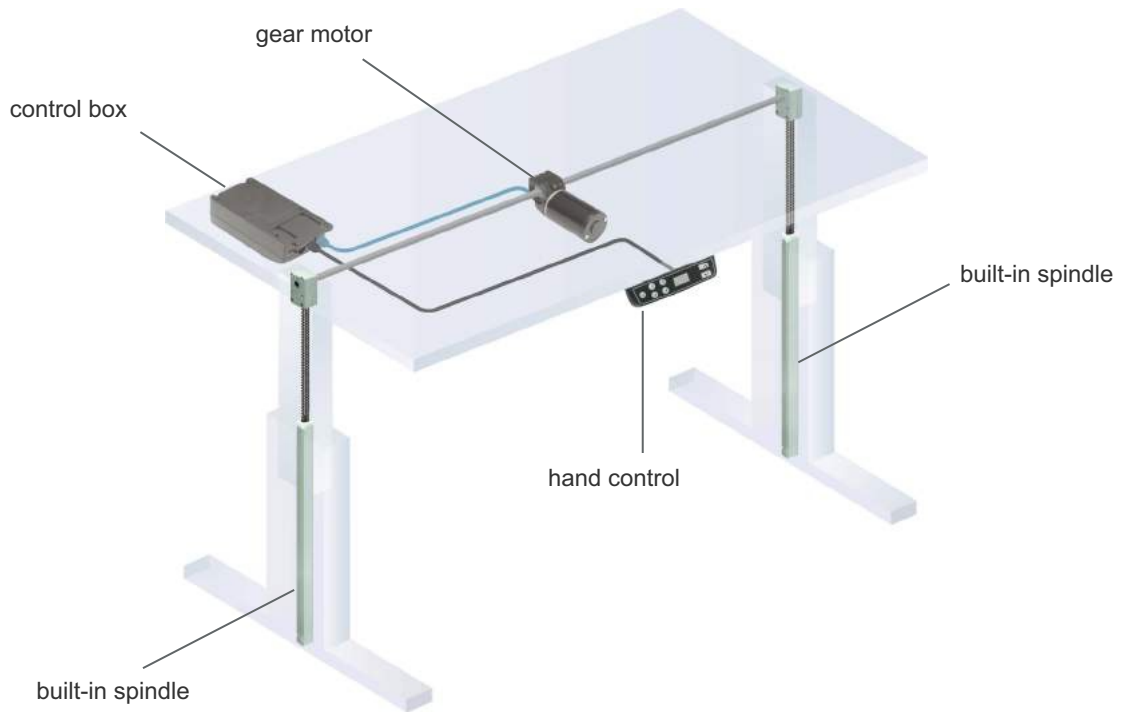

Performance Data

MTM4-LF (gear motor)

No.	Model No.	Drive torque Max. (Nm)	Typical Speed (rpm)	Typical Current (A) @ 24V		Dual Hall effect sensors resolution (ms)
			No load	No load	Full load	No load
①	MTM4-LF-24-A01-X-X	7	83	0.7	4	21~26
②	MTM4-LF-24-F02-X-X	7	110	0.7	5	16~20

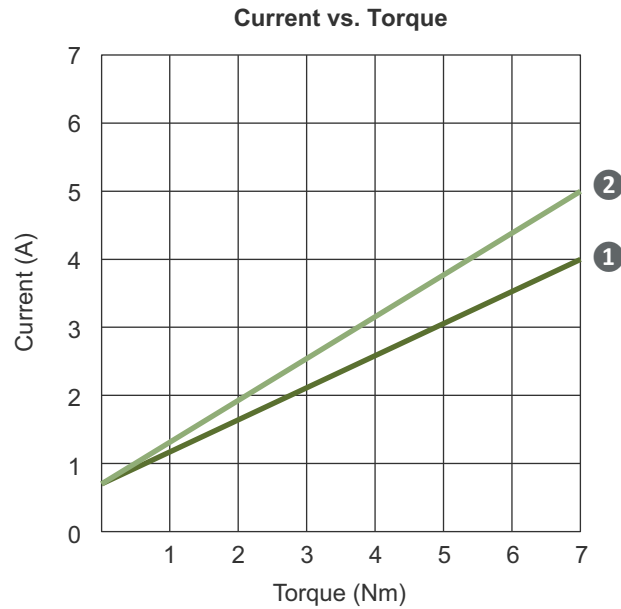

MTM4-LF (gear motor) + built-in spindle + control box combination of a lifting table.

No.	Model No.	Spindle lead (mm)	Max. load (kg)	Lifting Speed (mm/s)	
				No load	Full load
①	MTM4-LF-24-A01-X-X	8	100	11.1	11.3
②	MTM4-LF-24-A01-X-X	12	100	16.6	15.1
③	MTM4-LF-24-F02-X-X	8	100	14.6	14.1
④	MTM4-LF-24-F02-X-X	12	100	21.9	18.0

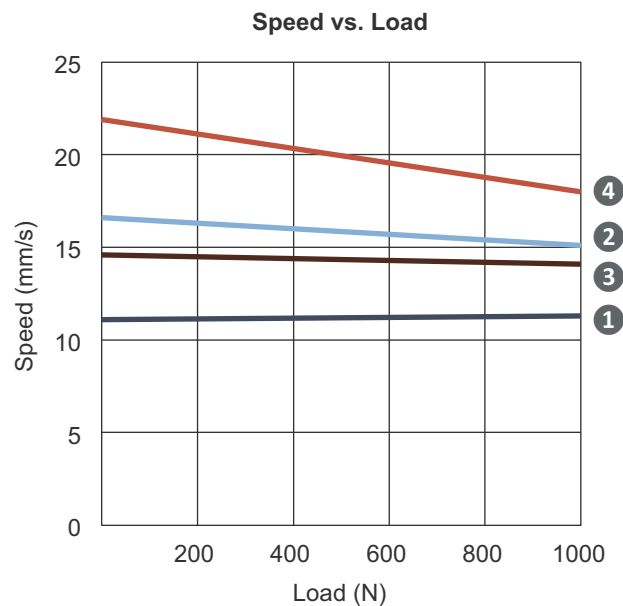

Dimensions

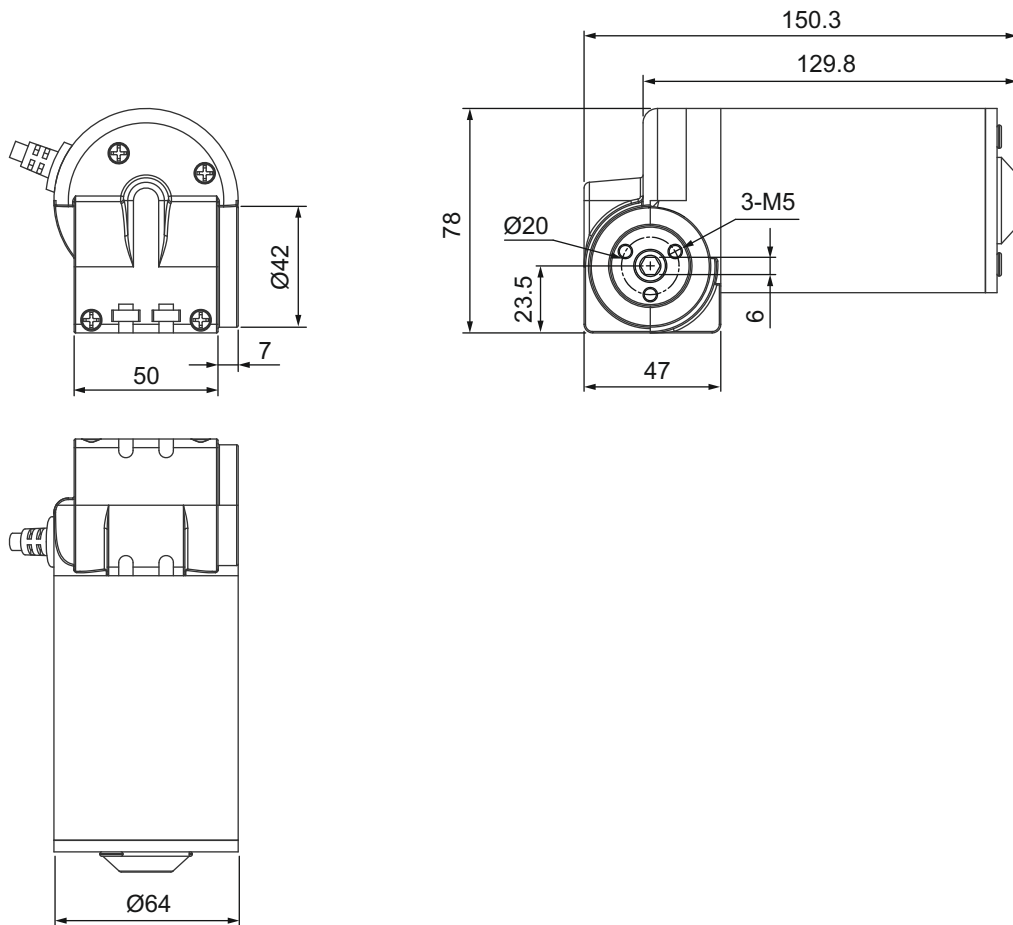

Cable Plug

L1-type or L3-type minifit plug

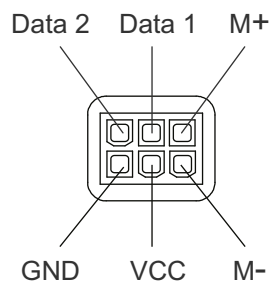

Note:

Connect Pin (M+) to "+" & Pin (M-) to "-" of DC power, the motor will turn counterclockwise.

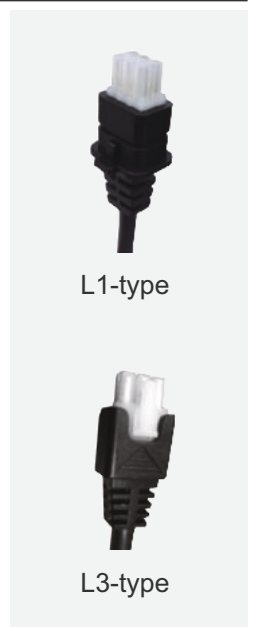
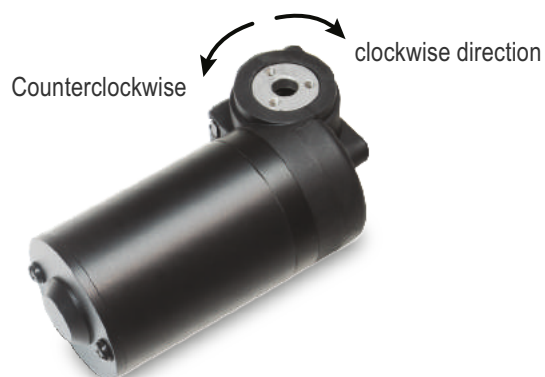

Ordering Key

MTM4-LF - 24 - A01 - 1 - 1

Input voltage	24: 24V DC
Motor type	A01: Standard motor (2500 rpm) F02: High speed motor (3300 rpm) (Refer to Performance Data)
Power cord length	1: 1000 mm straight
Cable plug	1: L1-type minifit 6-pin, 180° plug 2: L3-type minifit 6-pin, 180° plug (Refer to Dimensions)

Terms of Use

The user is responsible for application suitability of Modico products. As ongoing improvement process continues, products listed on the Modico website are subject to change without prior notice. Modico reserves the right to terminate the sales or remove any product displayed on the website, or listed in its catalogues.